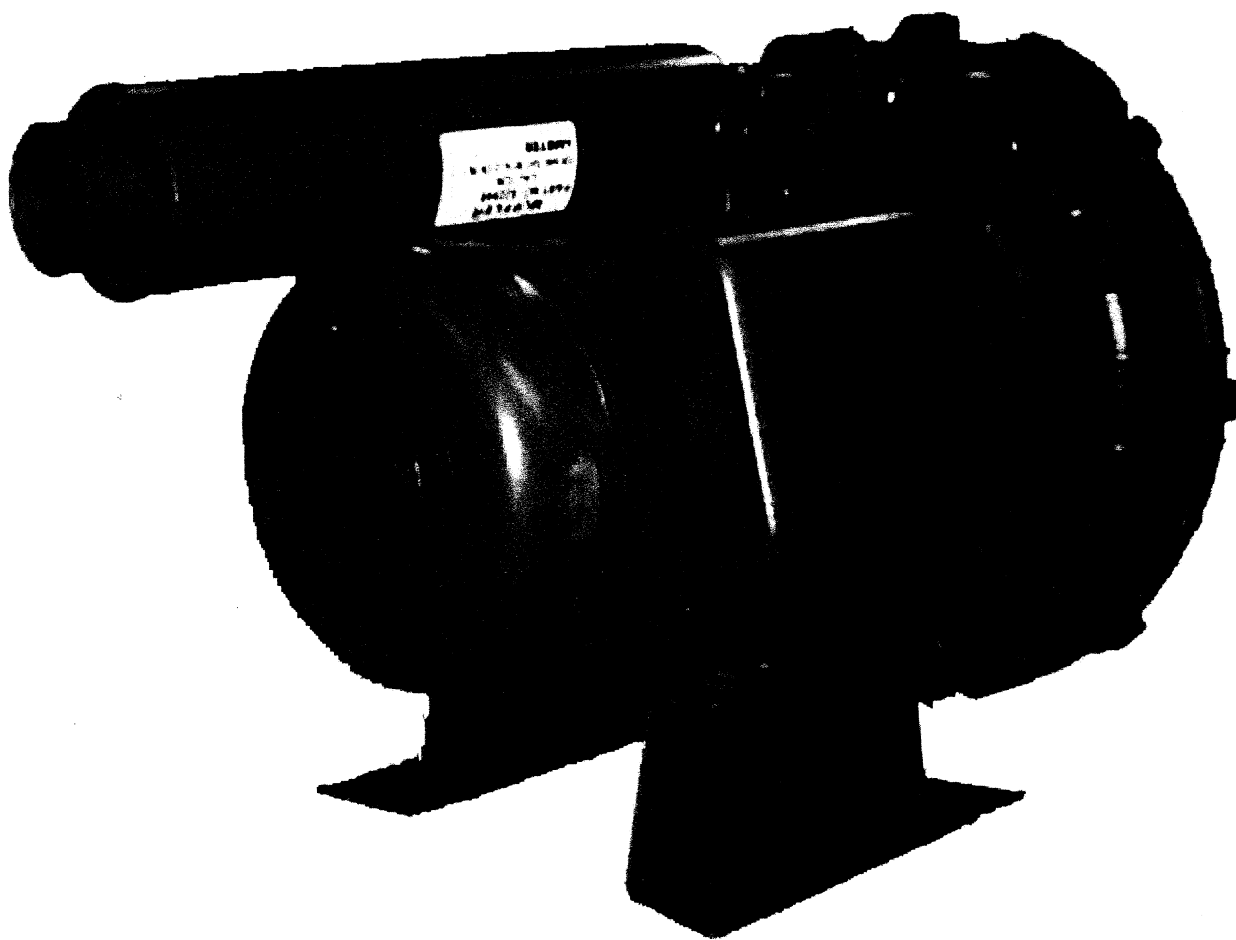


# VACU-MAID®

## CR-1400 SERIES

## INSTRUCTION MANUAL



# Lindsay Built-In Vacuum Systems

Lindsay Manufacturing, Inc. P.O. Box 1708 / 580-762-2457 / Ponca City, OK 74602-1708 / Fax 580-762-9547

## CR-1451/CR-1453/CR-1463 SERIES APPLICATIONS

The Series induction motor power units were designed specifically to be used in semi-commercial and commercial applications. These units are equipped with transformers, relays and an enclosed 24-volt low voltage remote control panel, that acts as the motor starter. These make ideal units for dental operations, restaurants, small motel and apartment complexes, nursing homes, service stations and other small businesses. The series consists of three major components, the power unit, which is an induction motor directly connected to a regenerative blower, and the primary dirt separator/collector and the secondary dirt separator/collector. The voltage and motor type will depend on the needs of the specific applications for which it was installed.

### POWER UNIT SPECIFICATIONS

MODEL	MOTOR	AMPS	H.P.	VAC"H <sub>2</sub> O	CFM	SHIPPING WGHT.
CR-1453A	230	17.6	5.0	105	225	148
CR-1453B	460	8.8	5.0	105	225	148
CR-1453C	208	19.5	5.0	105	225	148
CR-1451	230-1	25.0	5.0	105	225	148

Remote Control	24 Volt					
Induction Motor R.P.M.	3450	@ 60 Hz.				
	2850	@ 50 Hz.	4.8	198.0cm	5.4CMM	

CR1463A	230	17.6	5.0	105	225	148
CR1463B	460	8.8	5.0	105	225	148
CR1463C	208	19.5	5.0	105	225	148
CR1461	230-1	25.0	5.0	105	225	148

Remote Control	24 Volt					
Induction Motor R.P.M.	3450	@ 60 Hz.				
	2850	@ 50 Hz.	4.8	198.0cm	5.4CMM	

#### PRIMARY DIRT SEPARATOR/COLLECTOR FOR CR-1463/CR-1461 SERIES SPECIFICATIONS (DC-1400)(See page 9)

#### PRIMARY DIRT SEPARATOR/COLLECTOR FOR CR-1451/CR-1453 SERIES SPECIFICATIONS (DC-1200/DC-MCC)

DIAMETER	21"	DIAMETER	13-5/8"
HEIGHT	62"	HEIGHT	37-3/8"
DIRT CAPACITY	Approx. 24 Gallons	DIRT CAPACITY	Approx. 27 quarts
SHIPPING WEIGHT	Approx. 188 lbs.	SHIPPING WEIGHT	Approx. 23 lbs.

INLET AND OUTLET CONNECTIONS 2"

#### SECONDARY DIRT SEPARATOR/COLLECTOR SPECIFICATIONS (DC-500/DC-D)

DIAMETER_____	12-1/2"
HEIGHT _____	18-3/8"
DIRT CAPACITY_____	Approx. 24 quarts
SHIPPING WEIGHT_____	Approx. 10 lbs.

**NOTE:** Optional Dirt Canisters are available, see page 9.

## SAFETY INSTRUCTIONS



This is the safety alert symbol. When you see this symbol, personal injury is possible. The degree of injury is shown by the following signal words:

**DANGER:** Severe injury or death will occur if hazard is ignored.

**WARNING:** Severe injury or death can occur if hazard is ignored.

**CAUTION:** Minor injury or property damage can occur if hazard is ignored.

Review the following information carefully before operating or continuing with installation.

### General Information

**DANGER:** Do not pump flammable or explosive gases or operate in an atmosphere containing them. Ambient temperature for normal operation should not exceed 40 degrees C (105 degrees F). For higher ambient operation, consult the factory. Blower performance is reduced by the lower atmospheric pressure of high altitudes. If it applies to this unit, consult an LMI distributor or the factory for details.

### Installation

**WARNING:** Electric shock can result from bad wiring. Wiring must conform to all required safety codes and be installed by a qualified person.

Grounding is required.

The LMI blower can be installed in any position. The flow of cooling air over the blower and motor must not be blocked.

**Plumbing** - The tubing ports are designed as connection ports only and will not support the plumbing. Be sure to use the same or larger size tubing and fittings to prevent air flow restrictions and over-heating of the blower. Care should be taken so dirt and chips, often found in new plumbing, will not be allowed to enter the blower.

**Noise** - To reduce noise and vibration, the unit should be mounted on a solid surface that will not increase sound. The use of shock mounts or vibration isolation materials is recommended. If needed, inlet or discharge noise can be reduced by attaching muffler assemblies (see accessories).

**Rotation** - The blower should only rotate clockwise as viewed from the electric motor side. This is marked with an arrow in the casting. Proper rotation can be confirmed by checking air flow at the IN and OUT ports. On blowers powered by a three phase motor, rotation is reversed by changing any two of the three power wires.

### Operation

**WARNING:** Solid or liquid material exiting the blower or piping can cause eye damage or skin cuts. Keep away from air stream.

**CAUTION:** Attach blower to solid surface before starting to prevent injury or damage from unit movement. Air containing solid particles or liquid must pass through a filter before entering the blower (see accessories list for filter suggestions). Blowers must have mufflers, filters, other accessories and all tubing attached before starting. Any foreign material passing through the blower may cause internal damage.

**CAUTION:** Outlet tubing can burn skin. Guard or limit access.

Mark "CAUTION Hot Surface - Can cause burns."

Air temperature increases when passing through the blower. Three to five feet of metal tubing is required from the exhaust of the unit.

The blower must not be operated above the limits for continuous duty. Do not close off inlet (for vacuum) to reduce extra air flow. This could cause added heat and motor load.

**ACCESSORIES** - The LMI pressure/vacuum relief valve, DRV-330, will limit the operating duty by admitting or relieving air. The relief valve also allows full flow through the blower when the relief valve closes.

### Servicing

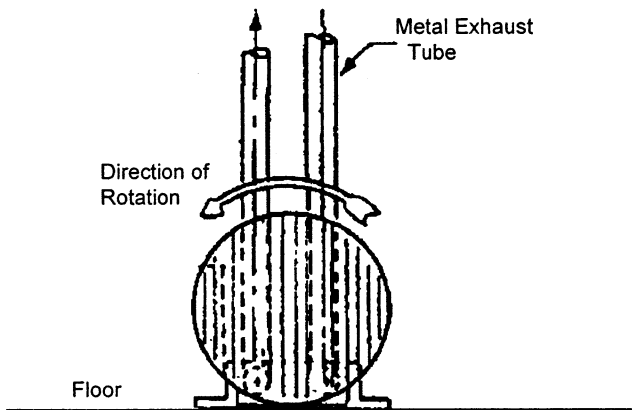
**WARNING:** Disconnect electric power before servicing. Be sure rotating parts have stopped. Electric shock or severe cuts can result. Inlet and exhaust filters need occasional cleaning or replacement of the elements. Failure to do so will result in more pressure drop, reduced air flow and hotter operation. The outside of the unit requires cleaning of dust and dirt. The inside of the blower may also need cleaning to remove material coating the impeller and housing. If not done, the buildup can cause vibration, hotter operation and reduced flow. Noise absorbing foam in the mufflers may need replacement. **KEEP THIS INFORMATION WITH THE BLOWER. REFER TO IT FOR SAFE INSTALLATION, OPERATION OR SERVICE.**

## INSTALLATION

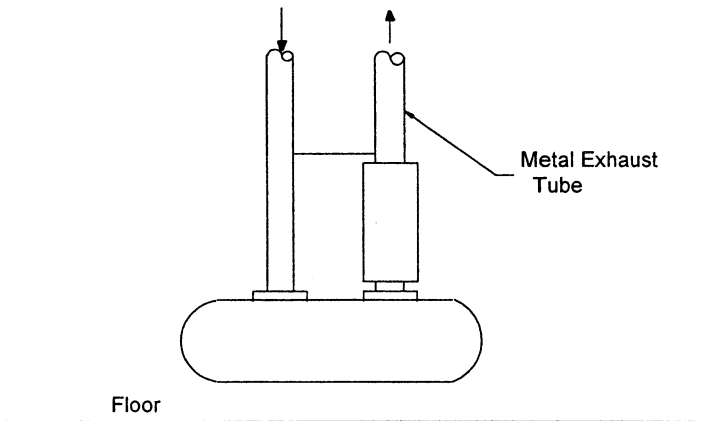
The CR-1451/1453 units are shipped in three separate cartons. One carton contains the primary dirt separator/collector (dirt canister), while the other cartons contain the motor and pump assembly and the secondary dirt separator/collector. Upon receipt you should carefully unpack all three units and inspect them for any shipping damage. After verifying that there has been no shipping damage the next step is to determine where and how the power unit and dirt canisters are to be mounted.

### MOUNTING

When determining where you are going to mount the power unit and dirt canisters, several factors should be taken into account. First, make certain you are choosing a location that is easily accessible for routine maintenance. Be certain that electrical power can be brought to the pump easily. It is recommended that these units be exhausted outdoors, so we would suggest mounting on or near an outside wall. The exhaust should be low to the ground to prevent radiation of noise. Once you have done this, choose which of the two suggested mounting formats shown below as figures 1, and 2, best suits your needs:

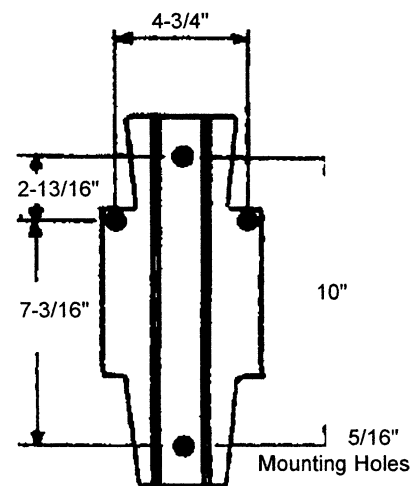


**FIGURE 1**  
Motor/Pump mounted on floor



**FIGURE 2**  
Motor/Pump mounted on Wall

If mounting on the wall you should use either 2" x 4" s or 2" x 8" s fastened to the studs to act as a mounting supports to help hold the unit. Once you have determined which method of mounting you will use, mount the motor/pump assembly first. The dirt canisters should always be mounted on the wall. We recommend that you mount the top of the can at least 4 feet off the floor, measuring from the floor to the top of the dirt canister. This should allow you at least six inches of clearance from the base of the can to the floor. By maintaining this measurement you will make certain that there is enough clearance to remove the bottom can for emptying while still making the the removable top easily accessible so that area can be cleaned. Once you have established your height measurement mount the wall hanger brackets (see figure 3). This hanger is equipped with 4 holes each having rubber grommets 1" in diameter with 5/16" center holes for anchoring bolts. Be sure to use 1/4" x 1-1/2" lag bolts and large diameter washers under the head of each bolt so the bolt will not slip through the rubber grommet.



**FIGURE 3**  
Dirt Canister Wall Hanger Bracket

Once the motor/pump assembly and dirt canisters have been mounted connect 2" plastic PVC tubing between the exhaust port of the dirt canister and the inlet port of the motor/pump assembly. When connecting the tubing to the motor/pump assembly be certain that the tubing enters the end of the housing approximately 3/4" and is then glued in place. Next vent the exhaust port of the motor/pump assembly, using 2" aluminum or steel tubing for the first five feet then continuing with 2" PVC tubing, to either the outside wall or through the roof making certain that the outside vent is turned in such a manner so that no rain can enter the tubing (see figure 4).

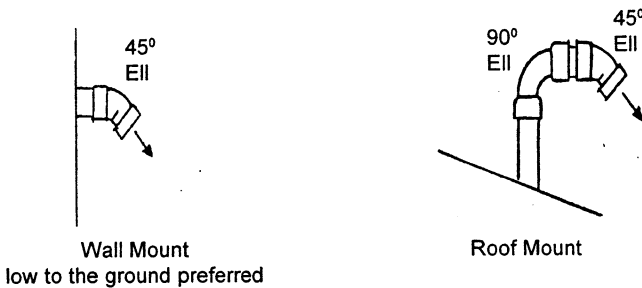


FIGURE 4

## WIRING

The next step in installation is to connect the power leads of the motor/pump assembly to incoming power. If you are connecting the 230-volt, single phase motor or the 230-volt, 208-volt or 460-volt, three phase motor use the directions and drawing shown in figure 5. Please note in some cases the markings on the relays L1,L2,L3 and T1,T2,T3 are reversed due to the mounting of the relay. Use good electrical practices in this case.

### Single phase:

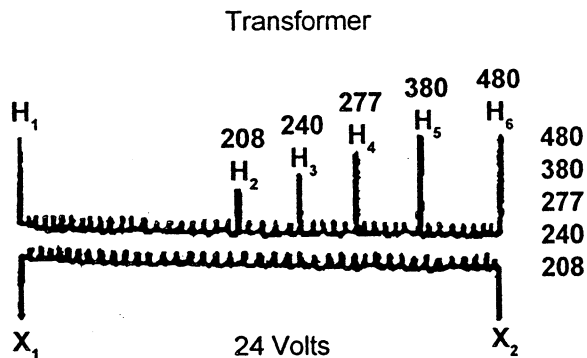
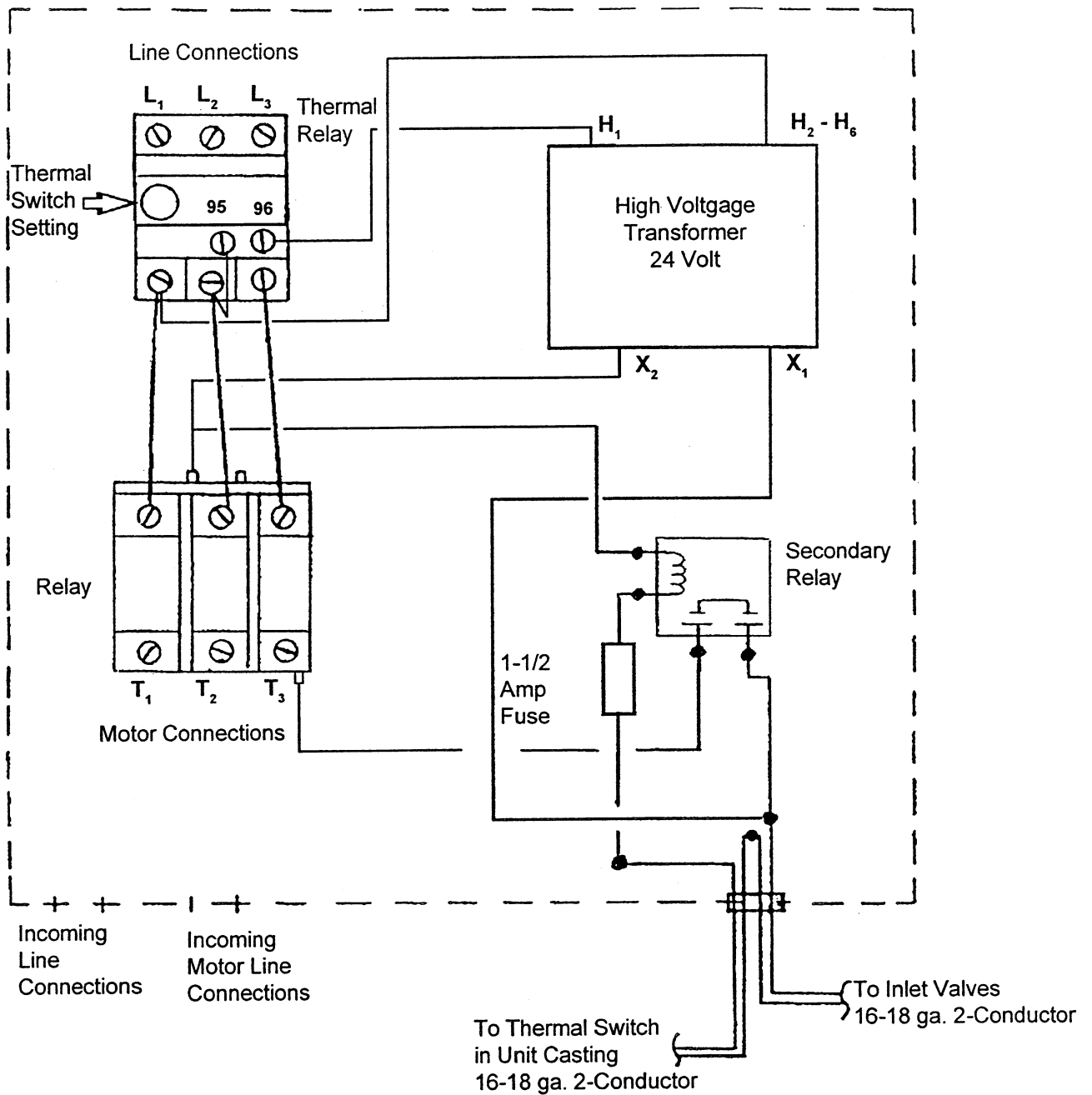
Connect one power lead to L-1 of the 3-pole relay and connect the second power lead to L-2. Connect your ground lead to a convenient location inside the remote control box. You do not need to worry about which lead goes to which connection, all single phase motors will make the pump rotate in the correct direction. The control box has a thermal overload relay. Check and make sure the relay is set for the proper amperage against the nameplate of the motor. Adjust if required.

### Three Phase:

Connect your incoming power leads as follows. Connect one lead to L-1 of the 3-pole relay, connect the second to L-2 and the third to L-3. Connect your ground lead to a convenient location inside the remote control box. Once you have made these connections it is necessary to check the pump motor for correct rotation. Start the motor and watch the direction of the shaft. The shaft should rotate in the direction of the arrow located on the motor housing (clockwise when facing the intake and exhaust ports). If it does not rotate in the proper direction let the motor come to a complete stop and then simply change any two of the three leads you have just connected (for example: interchange the L-2 and L-3 connections). **<THE MOTOR MUST COME TO A COMPLETE STOP BEFORE YOU CHANGE THE LEADS AND RESTART>** After doing this briefly start the motor again and check the shaft rotation. The shaft should now rotate in the correct direction. If it does not contact your distributor or Lindsay Manufacturing for further instructions. **UNDER NO CIRCUMSTANCES SHOULD YOU LET THE MOTOR RUN IN REVERSE FOR AN EXTENDED PERIOD OF TIME.** Once the shaft is rotating in the correct direction, connect the remote control wires as shown at the bottom of the remote control box (see figure 5).

To complete the installation connect the Vacuum Inlet on the Dirt Canister (lower connection) to the incoming 2" PVC tubing. Make certain that the tubing enters the inlet housing at least 3/4" and then glue in place. Next, connect the outlet (top connection) of the primary dirt canister to the secondary canister (top connection) then from the outlet of the secondary canister (bottom connection) to the vacuum pump intake port (left hand side viewed from motor end). Then run five feet of metal tubing from the exhaust port (right hand side) before using PVC tubing to exhaust to outside. Once this is completed the unit is ready for operation.

# CR-1400 Series Wiring Instructions for Control Box



**Note:** For single phase use T<sub>1</sub> and T<sub>2</sub> for motor connections, and L<sub>2</sub> and L<sub>1</sub> for line connections.

To reverse rotation on any three phase motor, interchange any two external motor line connections T<sub>1</sub> and T<sub>2</sub>.

Check the thermal relay setting to match the motor amperage.

## TROUBLE SHOOTING

The CR-1451/1453 units use two protective devices inside the motor/pump assembly. The first is a thermal switch located in the pump housing that will operate when the pump is moving less than 30 cubic feet of air per minute. This thermal switch prevents the blower from overheating and is set for 212° F. Since the exhaust air can reach temperatures as high as 230° F. the five feet of aluminum or steel tubing allows the heat to radiate away from the pump quicker and also helps prevent the possibility of pump damage due to overheating. If this switch does turn the motor off it will require about two minutes for the thermal switch to reset. The second protective device is a thermal switch in the control box that will operate if the motor exceeds rated amperage. While it is very unusual for this switch to operate, if it does turn the motor off, it will require about 30 minutes for the pump and motor to cool off enough to resume operation. The major cause for this switch operating is low voltage, other things that can cause this switch to operate is a jammed turbine blade, too much lint inside the motor or the intake holes into the motor become blocked with dirt or lint. Since these pumps are designed to move a high volume of cubic feet of air per minute it should not be used in sealed applications where the pump must operate under sealed or low volume conditions. There are relief valves that will need to be installed when these pumps are used in dental operations or restricted air applications. *IF THE BLOWER OVERHEATS OFTEN, OR IF USAGE AT LOW AIRFLOWS IS ANTICIPATED UPON OCCASSION, A 3/8" HOLE CAN BE DRILLED IN THE TUBING TO ALLOW MORE COOLING AIR BETWEEN THE PUMP AND THE DIRT CANISTER. THIS HOLE SHOULD BE DRILLED ON THE BACKSIDE, OR UNDER, THE TUBING TO HELP REDUCE THE POSSIBILITY OF IT PICKING UP DUST.* For additional information see troubleshooting guide below:

TROUBLESHOOTING		
Symptom	Possible Diagnosis	Possible Remedy
Excess Vibration	Impeller damaged by foreign material Impeller contaminated by foreign material	Replace impeller Clean Impeller, install adequate filtration.
Abnormal Sound	Motor bearing failed Impeller rubbing against housing	Replace bearings Repair blower, check clearances
Increase in Sound	Foreign material can coat or destroy muffler foam	Replace foam muffler elements, trap or filter foreign material.
Blown Fuse	Electrical wiring problem	Have qualified person check fuse capacity and wiring.
Unit very Hot	Running at too high a pressure or vacuum	Install a relief valve

## MAINTENANCE

The only maintenance required for the CR-1451/1463 is the emptying of the dirt canisters, periodic cleaning of the upper safety screen and filter bags and periodic pump bearing lubrication (see chart below). To empty the dirt canister, release the two latches located on each side of the dirt can. This will allow the dirt can to drop about four inches which will enable you to clear the plastic cone. After emptying the dirt can replace it by pushing the dirt can firmly against the gasket on the bottom of the dirt separator. Once seated firmly in place hold there with either your knee or one hand while snapping the two latches closed. To clean the top safety screen simply remove the top covering then remove any accumulated debris, lint, or similar material. Be sure you replace the top lid when you are finished (see secondary canister).

## PUMP BEARING LUBRICATION

No Lubrication needed at start up. Bearing lubricated at the factory

## FEATURES

### POWER UNIT

There are two major design reasons why the series power unit is so ideally suited for commercial application. The first is the fact that the unit is powered by an induction motor. This means there are no brushes to wear out so the unit has an almost infinite life as compared to a unit powered by a series motor where brushes limit the length of service in a commercial application. Secondly, the series motor blower systems were designed so that they require approximately only three horsepower to move a maximum C.F.M. of air flow through a two inch opening. This means that while the motor is designed to operate at greater horsepower, since it is not required to operate at full capacity, the lifetime of the motor is increased.

The model series power units are also protected by a thermal switch in the casting and a thermal switch in the control box for over amperage. For more information on these see Trouble Shooting.

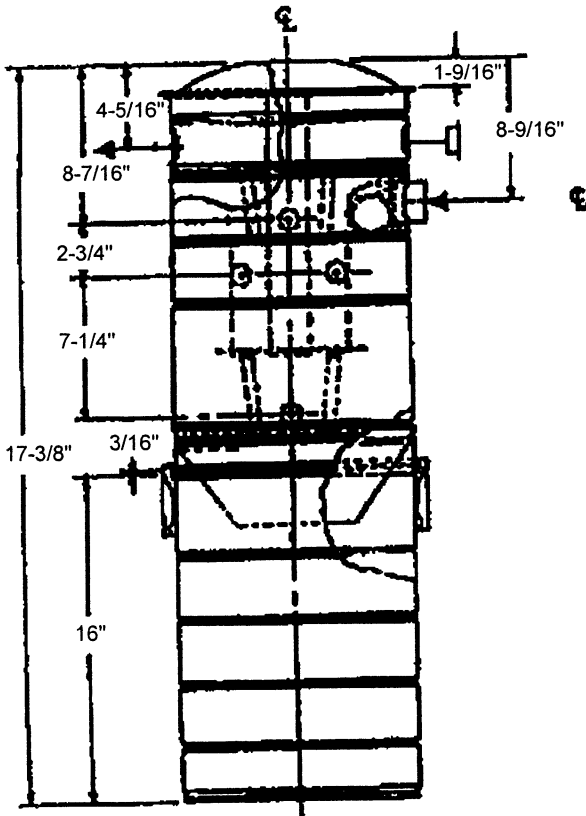
### MOTOR

Motors are designed to run within Class B limits. The stator windings are treated to assure maximum moisture protection while all machined surfaces in the motor are coated with a zinc chromate primer. The bearings in the motor are all prelubricated.

### DIRT CANISTERS

The series comes equipped with a DC-1200/DC-MCC and DC-500/DC-D Dirt Canisters as standard equipment. The DC-1200/DC-MCC dirt canister consists of two parts, the top part, or dirt separator, and the bottom part which is the actual dirt container.

The series with a DC-1200/DC-MCC Dirt Can is considered to be filter-free in that there is no paper, cloth or foam filter to be cleaned or changed. This is because the dirt separator is made up of two filtering or separating operations. As the unit is operating an air stream enters the canister through the two inch inlet tube. From there it is directed downward in a circular motion toward the bottom of the canister where the first filtering operation is carried out. This filtering is made by a plastic cone, which is mounted in the bottom part of the top canister. As the air stream flows down on this cone the heavier dirt particles are forced from the air stream and drop, through the cone, into the bottom dirt container. The air then continues back to the top of the canister where only the lighter, cleaner air passes through a tube called a standpipe and then through a safety screen. The air then continues through the exhaust outlet where it is then piped to the DC500/DCD secondary canister. However, keep in mind that the dirt container must be emptied periodically and at the same time the wire mesh screen (safety screen) should be checked (see Maintenance).

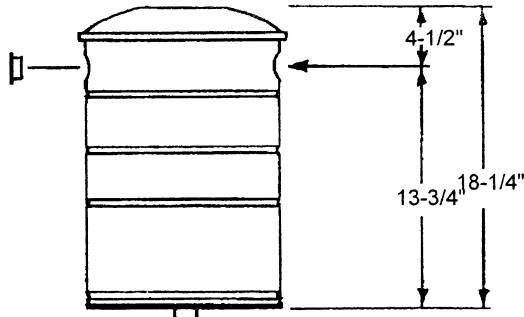


DC-1200  
(DC-MCC is comparable)

### SECONDARY DIRT CANISTER

Also with the series is a DC-500/DC-D dirt can that is used for fine dust control and as a secondary separator. The DC-500/DC-D comes with an HFB-4 reusable four layer fabric bag. To clean, just lift off the top lid and remove the bag. Then unzip the side zipper and dump the debris into a suitable container. After dumping the debris shake the bag to remove any excess dust. Rezip

the bag and place it back in the canister making sure that the 2" hole on the bag collar fits back over the 2" tubing in the canister. **NOTE:** if there is a noticeable reduction in airflow or cleaning capability check to be sure the bag is clean.

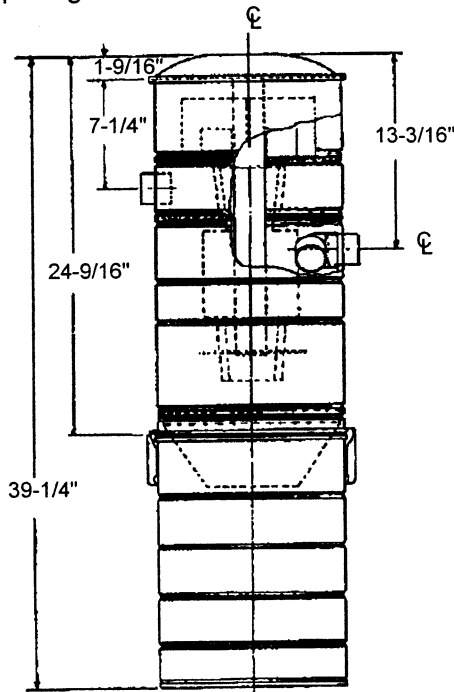


**DC-500**  
(DC-D is comparable in design)

**OPTIONAL EQUIPMENT**

**DC-1100/DC-MC Dirt Canister**

This dirt can operates in the same manner as the DC-1200/DC-MCC except that it incorporates three foam filters in the top. If the DC-1100/DC-MC dirt can is used an additional maintenance requirement is added. The three foam filters need to be checked each time the dirt canister is emptied, somewhat in the same manner that you would check the air filter on your car. If you notice a reduction in airflow or a loss of cleaning capability the three foam filters will need to be cleaned. To clean simply wash with water and then let completely dry before putting the filters back in the dirt can.



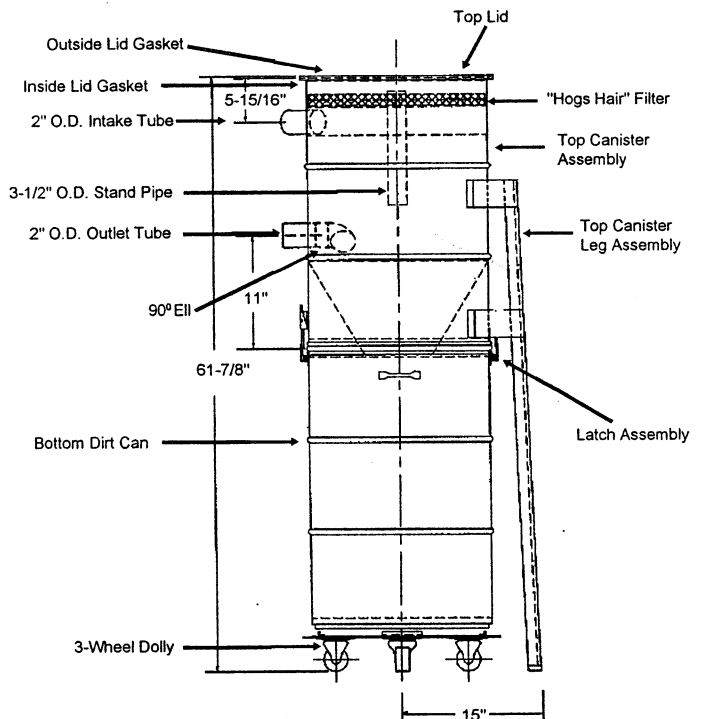
**DC-1100 Dirt Canister**  
(DC-MC is comparable in design)

**MUFFLER**

The unit is furnished with an exhaust muffler. Install the exhaust muffler on the back of the pump housing to the outlet marked out. Then install five feet of metal tubing to the exhaust muffler before attaching PVC tubing to the exhaust.

**DC-1400 DIRT CANISTER**

This dirt can operates in the same manner as the DC-1200/DC-MCC except that it has a roll out bottom dirt canister with approximately 24 gallons capacity. The DC-1400 dirt canister consists of two parts. The separator canister, or top part, is made of heavy gauge steel and is mounted on three legs. The bottom canister, which is also made of heavy gauge steel, is mounted on a three wheel dolly so it can be easily moved for emptying. The separator canister contains a three stage filter to help collect the foreign material. The first stage of the filtering process consists of the cyclonic cone that separates the heavier dirt as it enters the canister. The air then passes into the second stage, the stand pipe, that will let only the cleaner air out while insuring that the heavier dirt has dropped into the bottom canister. From the stand pipe the air passes into the third filter stage, that of the safety screen, or "hogs hair" type filter. This filter then collects those particles that were not heavy enough to be separated earlier, before passing the air into the vacuum pump where it is vented outside.



**DC-1400 Dirt Canister**

## DC-750 DIRT CANISTER

The DC-750 is a secondary filter used only for fine dust control (3 to 5 microns) and has a filtering area of about 37 square feet. The DC-750 uses a cartridge filter (FC-750). The DC-750 is the same size as the DC-500. For applications contact the factory.

## DRV-330 BLOWER RELIEF VALVE OPERATING INSTRUCTIONS

The DRV-330 air relief valve is furnished with your system and is pre-set at the factory. However, after installation of the relief valve please check at start up to verify the setting. Dental operations require 40" to 60" H<sub>2</sub>O, and other applications may require less vacuum. As a result the DRV-330 relief valve may need to be reset. In order to reset the valve please use the following instructions.

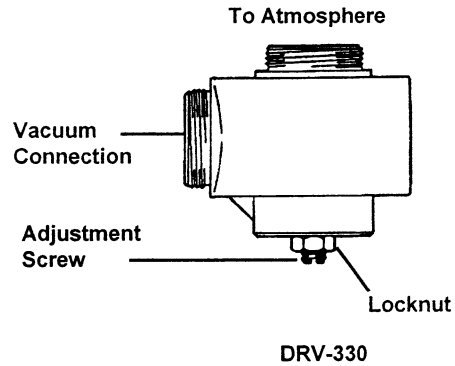
Operating the regenerative blowers with more than 1 HP motors and insufficient air flow can result in damage to the blower caused by excessive heating of the air passing through the blower.

The DRV-330 blower relief valve can be adjusted to limit the vacuum level and maintain adequate air flow through the blower to prevent damage from excessive heat. The relief valve should not be set for more than the maximum rating found on the motor name plate. **NOTE: Vacuum setting of the DRV-330 cannot exceed maximum vacuum rating on the nameplate of the CR-1400 and CR-1500 series units.**

Setting the DRV-330 Vacuum Relief Valve must be done before the vacuum tubing is glued or permanently set in place. Use the Vacuum gauge - VG-160 - to set the vacuum. Disconnect the vacuum line from the tee coming from the secondary filter and place the rubber stopper of the vacuum gauge over the end of the tee. This is the end which is to go to the secondary filter. **Caution: DO NOT** connect any vacuum line to the atmosphere opening of the relief valve. The atmosphere opening is to bleed air into the vacuum system to help cool the pump.

**Caution:** The relief valve must be placed in the vertical position with the adjusting screw pointing straight down. Failure to do so could result in incorrect relief valve vacuum settings.

The adjusting of the relief valve is accomplished by loosening the lock nut on the adjusting screw and turning the adjusting screw with the blade of a screwdriver. Turning the adjusting screw clockwise will increase the relief valve setting and counter clockwise will decrease the setting.



Hold the screwdriver in place when retightening the lock nut. The use of the vacuum (VG160) gauge will provide an accurate setting.



2-5/8" diameter  
0 - 160 in. H<sub>2</sub>O

VG-160  
Vacuum Gauge

**CAUTION:** For units with air flows exceeding 200 CFM two relief valves, in some cases, should be used in parallel to provide proper cooling to the blower. Contact the factory for further information.

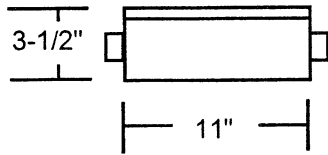
**CAUTION:** The RS330 relief valve safety screen coupler must be installed on the atmosphere side to prevent foreign objects from dropping into the DRV330 Relief Valve. Check safety screen each month for debris that may cause air restrictions.

All components of the valve are made of corrosion resistant metal. In normal operation the only maintenance required is cleaning the valve with WD-40. Often the valve need not be disassembled to clean. Particular attention should be given to cleaning the small hole through the center of the piston. If this becomes clogged the valve will not function properly. A pin or small diameter wire may be used to clean the blocked valve.

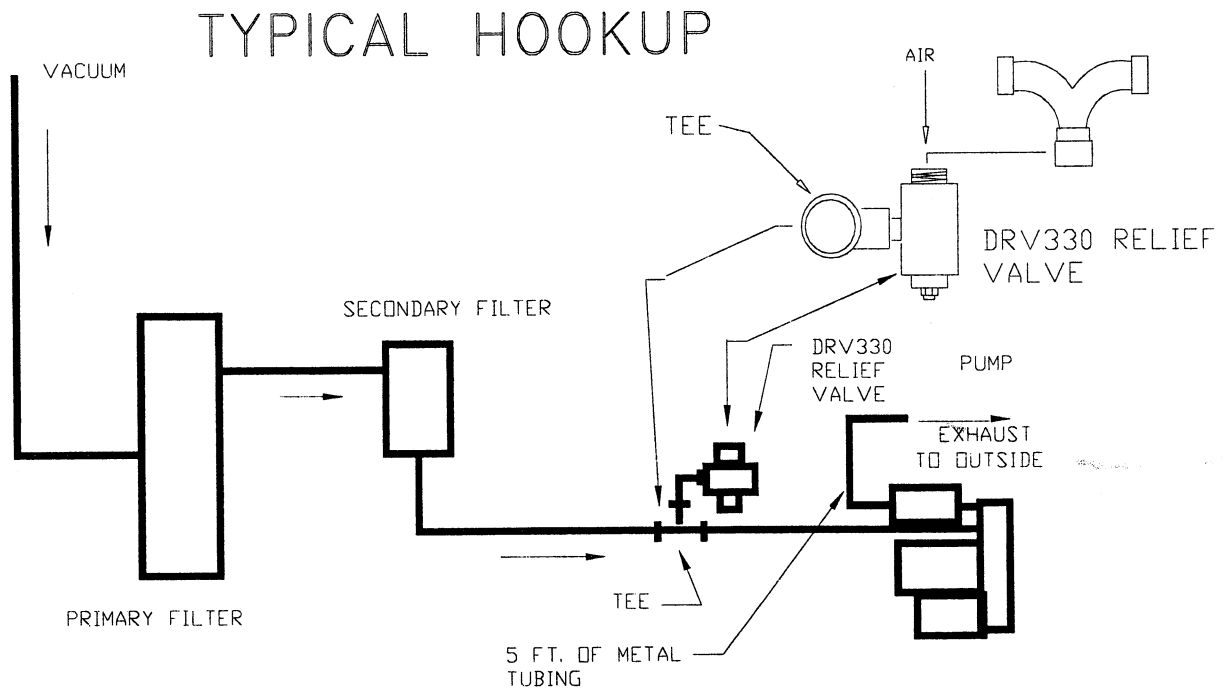
**NOTE:** For auto body applications and fine dust control the DRV-330 needs to be placed between the vacuum pump and secondary filter.

**WARNING: WHEN INSTALLING THE VACUUM RELIEF VALVE, ALL POWER SOURCES TO THE ELECTRIC MOTOR AND ANY ACCESSORY DEVICES SHOULD BE DISCONNECTED AND ALL ROTATION PARTS SHOULD BE AT A STANDSTILL OR BODILY INJURY COULD RESULT.**

**NOTE:** For best results the relief valve should be installed between the vacuum pump and secondary filter. A PF-200S (shown below) may be required on the relief valve in some cases. Remember the use of the VG-160 may be required to provide an accurate setting after installation. A filter may be required in dirty applications on the atmosphere side of the relief valve to prevent dirt from getting in the relief valve.



**PF-200S  
Muffler**



# COMMERCIAL / INDUSTRIAL LIMITED WARRANTY

**This Warranty (valid in the United States only) gives you specific legal rights, you may also have other rights which vary from State to State.**

## **ITEMS COVERED**

The commercial pump of your LMI Vacuum System is hereby warranted against defects in material and workmanship, to the original owner, for one (1) year following installation. This Warranty is effective upon date of installation until the original purchaser ceases to own the system or the system is removed and is not extended by the replacement or repair of component parts.

## **ITEMS NOT COVERED**

This Warranty does not cover such conditions as normal wear or from damage caused by accidents, negligence, misuse, or improper alteration, or from damage by fire, flood, or other acts of God. Muffler wear is normal and is not considered to be a defect in material or workmanship. Further, this Warranty does not apply to flexible hoses, wands and cleaning tools, or to the act of installing the LMI Commercial/Industrial Vacuum System.

## **HOW TO INVOKE THIS WARRANTY**

If it should ever become necessary to invoke the rights and privileges of this Warranty the original purchaser should contact the installer or distributor. The distributor shall repair or replace, at Lindsay Manufacturing's sole option, such parts that maybe found to be defective. Such labor charges that are deemed necessary and proper shall be the responsibility of the owner if repairs are necessary. Only repairs carried out using authentic Lindsay replacement parts and by an authorized LMI distributor shall be covered. If the LMI distributor-installer has not solved your problem within a reasonable time (but in all events within 45 days of when you became aware of a defect), write or call Lindsay Manufacturing, Inc., to obtain a return authorization number and delivery instructions for warranty service. All freight and/or removal charges incurred as a result of a return to the factory shall be the responsibility of the consumer. Proof of purchase is required for all warranty claims.

## **DISCLAIMER OF OTHER WARRANTIES**

LINDSAY MANUFACTURING, INC., HEREBY DISCLAIMS ALL LIABILITY WHATSOEVER FOR ANY INCIDENTAL OR CONSEQUENTIAL DAMAGES WHICH OCCUR AS A RESULT OF DEFECTS IN MATERIAL AND WORKMANSHIP IN THE PRODUCT. LINDSAY MANUFACTURING, INC., ALSO HEREBY DISCLAIMS ALL IMPLIED WARRANTIES, INCLUDING THE WARRANTIES OF MERCHANTABILITY AND FITNESS FOR A PARTICULAR PURPOSE.

SOME STATES DO NOT ALLOW THE EXCLUSION OR LIMITATION OF INCIDENTAL OR CONSEQUENTIAL DAMAGES, SO THE ABOVE LIMITATION OR EXCLUSION MAY NOT APPLY TO YOU. SOME STATES DO NOT ALLOW LIMITATIONS ON HOW LONG AN IMPLIED WARRANTY LASTS, SO THE ABOVE LIMITATIONS MAY NOT APPLY TO YOU. TO THE EXTENT THAT ANY LAW PROHIBITS, IN WHOLE OR PART, THE LIMITATION OF IMPLIED WARRANTIES, ANY IMPLIED WARRANTY APPLICABLE TO THE PRODUCT SHALL NOT EXCEED ONE (1) YEAR IN COMMERCIAL OR INDUSTRIAL APPLICATIONS.

This warranty is exclusive and is in lieu of all other expressed warranties, and in lieu of all other obligations or liabilities on the part of Lindsay Manufacturing, Inc., for damage to person or property. We do not authorize any person, including any dealer, agent, supplier, or representative of Lindsay Manufacturing, Inc., to make any other warranty or guarantee on our behalf, or assume for us any liability on the LMI Commercial/Industrial Vacuum System other than that contained herein. No oral representations regarding warranty shall be binding upon Lindsay Manufacturing, Inc., whether extended before or after sale of that product.

**LINDSAY MANUFACTURING, INC. / P.O. BOX 1708 / 580-762-2457 / PONCA CITY, OK 74602-1708**  
LMI is a registered trademark of Lindsay Manufacturing, Inc.